

3	Aggiunto neck lock e mod. ricer.	20/11/2017
2	Aggiornata "H"	05/09/2017
1	Aggiornata capacità	20/04/2017
REV	DESCRIZIONE	DATA

Data creazione - Date	Gen. Toll.	Scala - Scd	Mat. generico/interno - Raw Material
19/02/2015	$\pm 1 \%$	1:1	PET
Progettato da - Created by	Capacità RB - Volume (ml)	Peso - Weight (gr)	Mat. esterno - Raw Material 2
MZ	169 ± 3	23 ± 1.5	

Controllato da - Checked by	Descrizione - Description	N° Disegno - Drawing
	FLACONE MUSSEN 100ml BOTTLE MUSSEN 100 ml	F-0473-00



Application torque: 2.0 N-m-/+0.1 N-m
 18.0 lbf.in-/+0.9 lbf.in

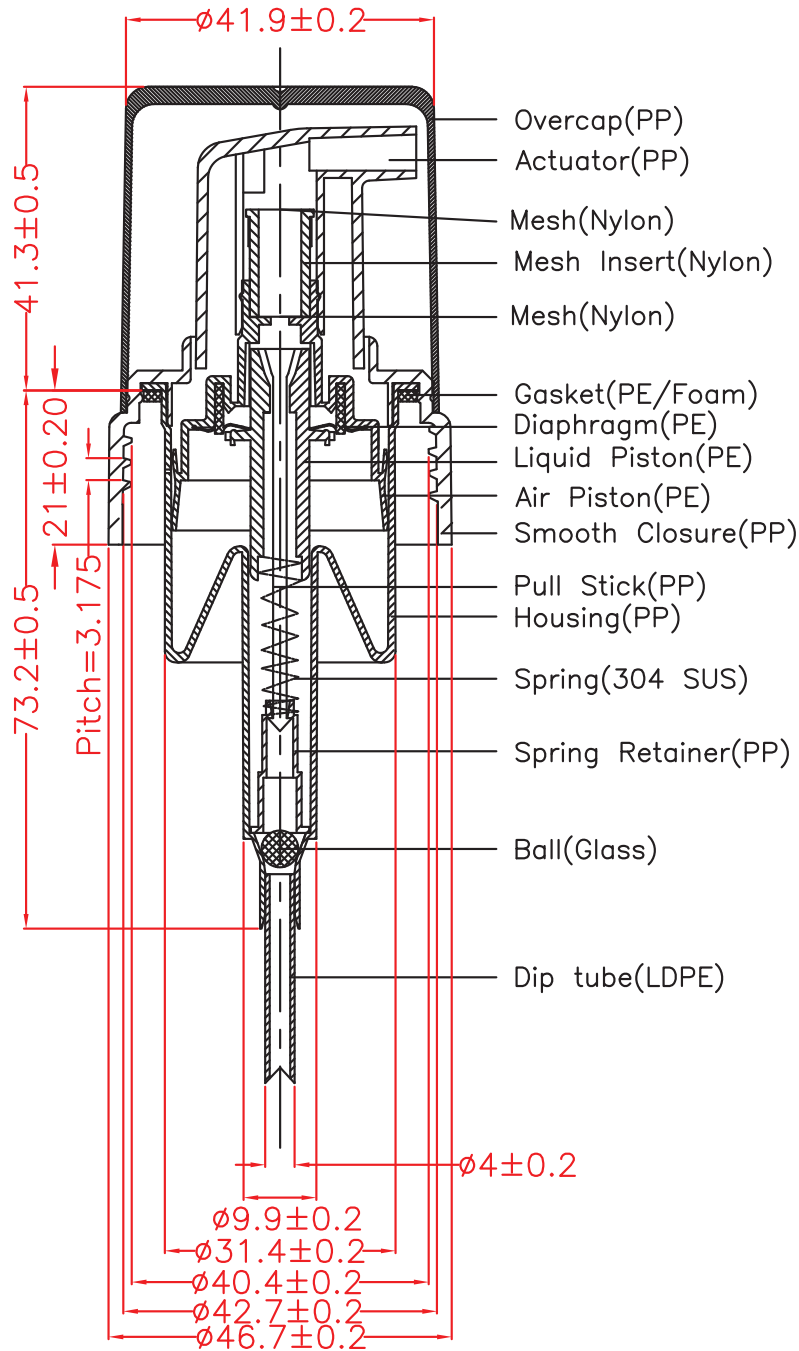

Note: All dimensions are in millimeters

CONFIDENTIAL

This document contains proprietary information of Arminak & Associates. Its receipt or possession does not convey any rights to reproduce or disclose its contents or to manufacture, use, or sell anything it may describe. Reproduction, disclosure, or use without specific written authorization of Arminak & Associates, Inc. is strictly forbidden.

43 mm 0.8 cc Foamer Pump

Rev.	Date	Description			
Date	12/03/09	Scale	1:1	Dwg code.	FP-F2S08D-43

Arminak & Associates

1350 Mountain View Circle , Azusa, CA 91702

Tel. (626)358-4804

Fax (626)358-4688

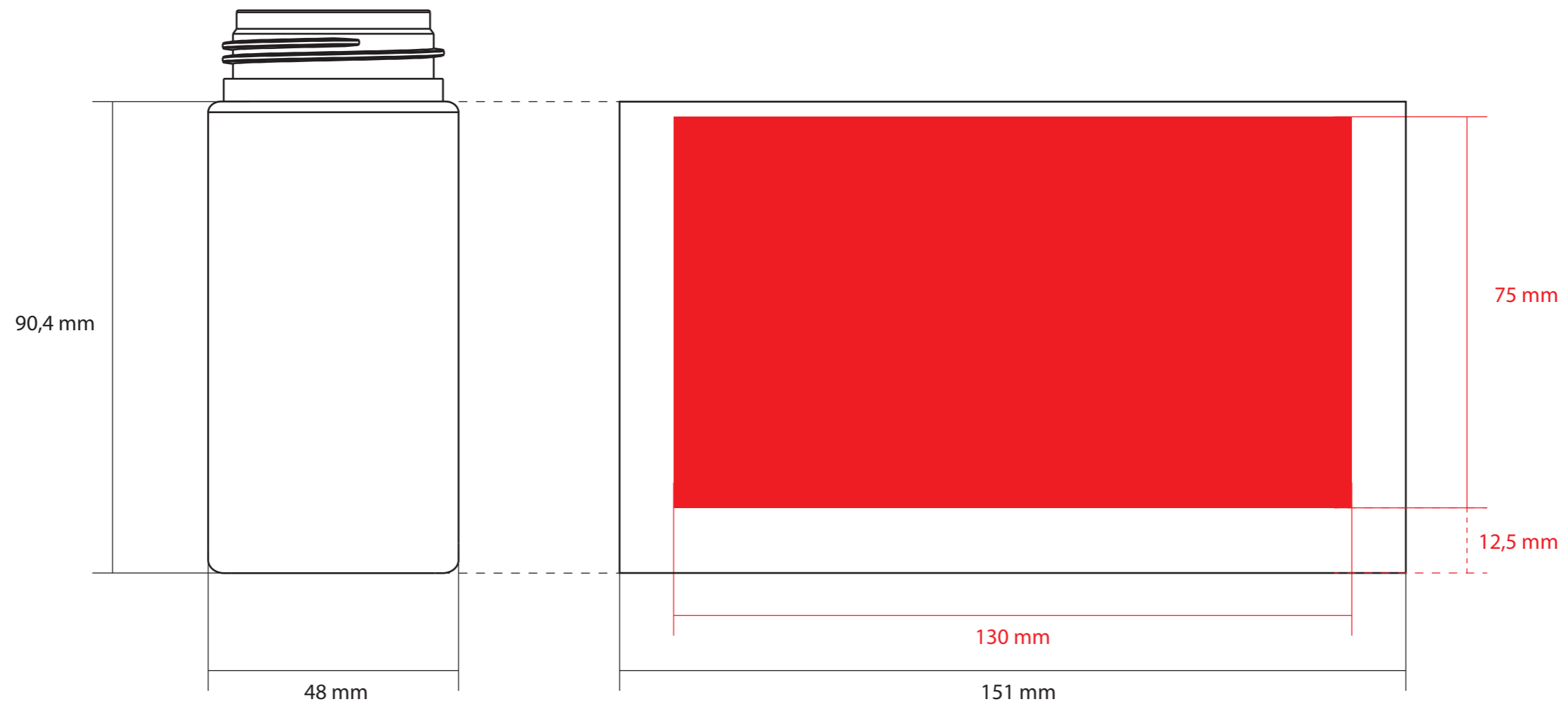

PRODOTTO: FLACONE FOAMER 100 ml

TECNICA STAMPA: SERIGRAFIA

